

THIS DOCUMENT CONTAINS INFORMATION THAT IS CONFIDENTIAL AND PROPRIETARY TO PARKER-HANNIFIN CORPORATION ("PARKER"). THIS DOCUMENT IS FURNISHED ON THE UNDERSTANDING THAT THE DOCUMENT AND THE INFORMATION IT CONTAINS WILL NOT BE COPIED OR DISCLOSED TO OTHERS OR USED FOR ANY PURPOSE OTHER THAN CONDUCTING BUSINESS WITH PARKER, AND WILL BE RETURNED AND ALL FURTHER USE DISCONTINUED UPON REQUEST BY PARKER. ALL RIGHTS RESERVED.

INSTRUCTIONS FOR A DUMP-PUMP ASSEMBLY ROTATION CHANGE (C102 / G102 / G104 / G105)

REFERRING TO THE DRAWINGS BELOW:

NOTE #1 - WHEN VIEWING A CW ASSEMBLY FROM THE SHAFT ENDCOVER WITH THE DRIVE SHAFT ON TOP AND THE IDLER GEAR ON BOTTOM, THE VALVE SPOOL WILL BE ON THE RIGHT SIDE OF THE PUMP.

NOTE #2 - WHEN VIEWING A CCW ASSEMBLY FROM THE SHAFT ENDCOVER WITH THE DRIVE SHAFT ON TOP AND THE IDLER GEAR ON BOTTOM, THE VALVE SPOOL WILL BE ON THE LEFT SIDE OF THE PUMP.

TO CHANGE ROTATION OF A PUMP, PROCEED AS FOLLOWS:

1. REMOVE THE FOUR FASTENERS HOLDING THE PUMP TOGETHER. 9/16"-12 FOR THE "G-SERIES" PUMPS AND 5/8"-11 FOR THE "C-SERIES" PUMPS. FASTENER TORQUE IS 2400 IN-LBS.
2. REMOVE THE VALVE-BODY ASSEMBLY.
3. REMOVE THE GEAR HOUSING. ROTATE THE HOUSING 180 DEGREES; MAINTAINING THE SAME GEAR BORE FOR THE DRIVE SHAFT. REPLACE THE GEAR HOUSING.
4. ROTATE THE VALVE-BODY 180 DEGREES FROM THE ORIGINAL POSITION AND REPLACE. NOTE. FOR C102 ASSEMBLIES THE PROTRUDING RIB ON THE GEAR HOUSING WILL ALWAYS BE ON THE OPPOSITE SIDE OF THE ASSEMBLY FROM THE VALVE SPOOL.
5. REPLACE THE FOUR FASTENERS AND TORQUE TO 2400 IN-LBS IN A DIAGONAL PATTERN.
6. VERIFY PROPER ASSEMBLY BY REFERRING TO NOTES #1 AND #2 ABOVE.

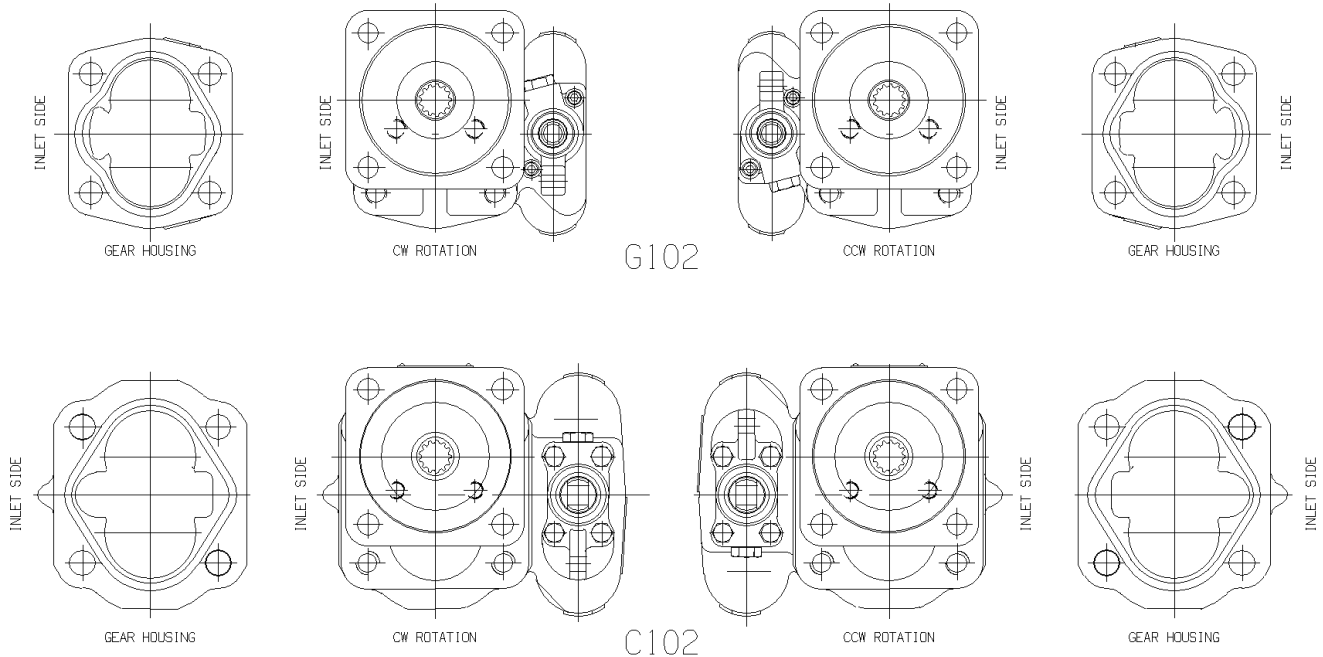

INSTRUCTIONS=(C102/G102)ASS'Y_ROTATION_CHG

Parker
Hydraulics

PARKER-HANNIFIN CORP.
GEAR PUMP DIVISION
YOUNGSTOWN, OH 44501
USA

EXP NO.			DR. BY	DATE	CH. BY	DATE	SCALE
FIRST USED		ADM CTR	TLE	092602	JBE	110402	FULL
02-07-455		REV					
		DTE					
		WT.					
391 1813 068		CODE					
	SYM.	REVISIONS	© 2002 PARKER-HANNIFIN CORPORATION				

THIS DOCUMENT CONTAINS INFORMATION THAT IS CONFIDENTIAL AND PROPRIETARY TO PARKER-HANNIFIN CORPORATION ("PARKER"). THIS DOCUMENT IS FURNISHED ON THE UNDERSTANDING THAT THE DOCUMENT AND THE INFORMATION IT CONTAINS WILL NOT BE COPIED OR DISCLOSED TO OTHERS OR USED FOR ANY PURPOSE OTHER THAN CONDUCTING BUSINESS WITH PARKER, AND WILL BE RETURNED AND ALL FURTHER USE DISCONTINUED UPON REQUEST BY PARKER. ALL RIGHTS RESERVED.

START-UP PROCEDURE FOR UNDERBODY APPLICATIONS (C102 / G102 / G104 / G105)

- 1- FILL THE CYLINDER WITH OIL PRIOR TO INSTALLING THE BED ON THE TRUCK. CYLINDER SHOULD BE HORIZONTAL AND IN RETRACT POSITION.
- 2- DURING THIS PROCEDURE TO MAKE SURE THE HYDRAULIC HOSES TO THE PUMP GET FILLED WITH OIL. PUT THE VALVE SPOOL ON THE PUMP IN "LOWER POSITION". IT MAY BE NECESSARY TO CRACK THE OUTLET LINE AT THE CYLINDER TO BLEED OFF THE TRAPPED AIR.
- 3- OPERATE THE PUMP AT LEAST TWO MINUTES AT ZERO PRESSURE AT LOWEST POSSIBLE RPM - THE BEST WAY TO DO THIS IS TO RUN THE PUMP WITH SPOOL IN "LOWER POSITION". DURING THIS BREAK-IN PERIOD, THE UNIT SHOULD RUN FREE AND NOT DEVELOP AN EXCESSIVE AMOUNT OF HEAT. IF THE UNIT OPERATES PROPERLY, PROCEED TO THE NEXT STEP.
- 4- CYCLE THE TRUCK BED UP AND DOWN 2-3 TIMES TO BLEED OFF ANY AIR. CHECK THE OIL LEVEL AND ADD ANY OIL IF NEEDED.

LUBRICATION AND OIL RECOMMENDATIONS

VISCOSITY RECOMMENDATIONS

OPTIMUM OPERATING VISCOSITY IS CONSIDERED TO BE ABOUT 100 SUS (20 cSt).

MINIMUM: APPROXIMATELY 50 - 60 SUS (7.5 - 10 cSt)

MAXIMUM AT START UP: APPROXIMATELY 7500 SUS (1600 cSt)

VISCOSITY GRADES NORMALLY USED

ISO GRADE	40°C	100°C
32	32 cSt	5 cSt
46	46 cSt	7 cSt

VISCOSITY IN FIRST COLUMN MAY VARY ±10% ACCORDING TO ISO STANDARDS. SECOND COLUMN FIGURES ARE BASED ON PUBLISHED INFORMATION FROM VARIOUS OIL COMPANIES.

OTHER DESIRABLE PROPERTIES

VISCOSITY INDEX: 90 MINIMUM

ADDITIVES USUALLY RECOMMENDED

RUST AND OXIDATION (R & O) INHIBITORS
FOAM DEPRESSANT

NOTE: ANTIWEAR (AW) ADDITIVES ARE NOT NECESSARILY RECOMMENDED. IN SOME INSTANCES THE PRESENCE OF ZINC COMPOUNDS CAN ACTUALLY BE HARMFUL TO COPPER, BRONZE, OR BRASS COMPONENTS USED IN THE SYSTEM. THE USE OF AW OIL IS OPTIONAL WITH OUR GEAR UNITS.

COLD WEATHER OPERATION

OILS FOR USE IN COLD WEATHER SHOULD HAVE A VISCOSITY NOT EXCEEDING 7500 SUS (1600 cSt) AT THE MINIMUM START-UP TEMPERATURE AND A POUR POINT AT LEAST 20° F (11° C) BELOW THAT TEMPERATURE. EXPERIENCE ON THE ALASKAN NORTH SLOPE HAS BEEN SATISFACTORY WITHOUT USING SPECIAL OILS OR FLUIDS. START-UP PROCEDURES MUST ALLOW FOR A GRADUAL WARM-UP AND EQUIPMENT SHOULD NOT BE OPERATED AT FULL PRESSURE UNTIL THE OIL REACHES A REASONABLY FLUID STATE.

NOTE: PLEASE CONSULT OUR PRODUCT SUPPORT DEPARTMENT WITH ANY QUESTIONS REGARDING THESE DIRECTIONS AND RECOMMENDATIONS.

INSTRUCTIONS=(C101/G101)LUBE_&_OIL_RECOMMENDATIONS						PARKER-HANNIFIN CORP. GEAR PUMP DIVISION YOUNGSTOWN, OH 44501 USA				
EXP NO.				ADM CTR	P	DR. BY	DATE	CH. BY	DATE	SCALE
FIRST USED				REV		TLE	092602	JBE	110402	FULL
02-07-455				DTE	000000					
391 1813 068				WT.		391 1813 068 2:2				
	SYM.	REVISIONS		CODE		© 2002 PARKER-HANNIFIN CORPORATION				